



PCT

WORLD INTELLECTUAL PROPERTY ORGANIZATION  
International Bureau

INTERNATIONAL APPLICATION PUBLISHED UNDER THE PATENT COOPERATION TREATY (PCT)

(51) International Patent Classification <sup>6</sup> : A61F 2/06, A61M 29/02	A1	(11) International Publication Number: <b>WO 97/21402</b> (43) International Publication Date: 19 June 1997 (19.06.97)
<p>(21) International Application Number: PCT/US96/19667</p> <p>(22) International Filing Date: 13 December 1996 (13.12.96)</p> <p>(30) Priority Data: 08/572,436 14 December 1995 (14.12.95) US 08/620,273 22 March 1996 (22.03.96) US</p> <p>(60) Parent Application or Grant (63) Related by Continuation US 08/620,273 (CIP) Filed on 22 March 1996 (22.03.96)</p> <p>(71) Applicant (for all designated States except US): PROGRAFT MEDICAL, INC. [US/US]; 2500 Faber Place, Palo Alto, CA 94303 (US).</p> <p>(72) Inventors; and (75) Inventors/Applicants (for US only): VAN DER BURG, Erik [US/US]; 587 Dawn Drive, Sunnyvale, CA 94087 (US). LEOPOLD, Eric [US/US]; 5195 Alan Avenue, San Jose, CA 95124 (US). REYES, Ramiro [US/US]; 32626 Muirwood Drive, Union City, CA 994587 (US).</p>	<p>(74) Agents: MACEY, Harry, J. et al.; Morrison &amp; Foerster L.L.P., 755 Page Mill Road, Palo Alto, CA 94304-1018 (US).</p> <p>(81) Designated States: AU, CA, JP, US, European patent (AT, BE, CH, DE, DK, ES, FI, FR, GB, GR, IE, IT, LU, MC, NL, PT, SE).</p> <p><b>Published</b> <i>With international search report.</i></p>	

(54) Title: STENT-GRAFT DEPLOYMENT APPARATUS AND METHOD

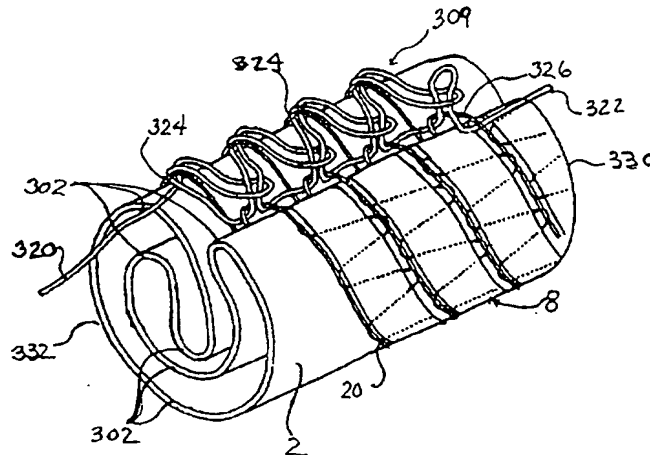

(57) Abstract

A stent or stent graft deployment apparatus or mechanism (320, 322) configured so that, when activated, the stent or stent graft (2) progressively expands in a direction from its first end which is proximally positioned to the deployment instrument, such as a percutaneous catheter, to its end which is distally positioned to the deployment instrument. The stent or stent graft deployment mechanism may include a tether or slip line configuration (306) that may minimize the likelihood of snagging between the line and stent member. A method is also provided for deploying a stent or stent graft within a mammalian lumen which includes expanding the stent or stent graft in such a proximal to distal direction. The apparatus and method of the present invention may minimize the likelihood of the stent or stent graft from being displaced from the desired site before it is somewhat secured in the vessel during deployment. The deployment means can facilitate expansion in a downstream to upstream direction where fluid flow in the lumen is downstream.

**FOR THE PURPOSES OF INFORMATION ONLY**

Codes used to identify States party to the PCT on the front pages of pamphlets publishing international applications under the PCT.

AM	Armenia	GB	United Kingdom	MW	Malawi
AT	Austria	GE	Georgia	MX	Mexico
AU	Australia	GN	Guinea	NE	Niger
BB	Barbados	GR	Greece	NL	Netherlands
BE	Belgium	HU	Hungary	NO	Norway
BF	Burkina Faso	IE	Ireland	NZ	New Zealand
BG	Bulgaria	IT	Italy	PL	Poland
BJ	Benin	JP	Japan	PT	Portugal
BR	Brazil	KE	Kenya	RO	Romania
BY	Belarus	KG	Kyrgystan	RU	Russian Federation
CA	Canada	KP	Democratic People's Republic of Korea	SD	Sudan
CF	Central African Republic	KR	Republic of Korea	SE	Sweden
CG	Congo	KZ	Kazakhstan	SG	Singapore
CH	Switzerland	LI	Liechtenstein	SI	Slovenia
CI	Côte d'Ivoire	LK	Sri Lanka	SK	Slovakia
CM	Cameroon	LR	Liberia	SN	Senegal
CN	China	LT	Lithuania	SZ	Swaziland
CS	Czechoslovakia	LU	Luxembourg	TD	Chad
CZ	Czech Republic	LV	Latvia	TG	Togo
DE	Germany	MC	Monaco	TJ	Tajikistan
DK	Denmark	MD	Republic of Moldova	TT	Trinidad and Tobago
EE	Estonia	MG	Madagascar	UA	Ukraine
ES	Spain	ML	Mali	UG	Uganda
FI	Finland	MN	Mongolia	US	United States of America
FR	France	MR	Mauritania	UZ	Uzbekistan
GA	Gabon			VN	Viet Nam

## STENT-GRAFT DEPLOYMENT APPARATUS AND METHOD

### BACKGROUND OF THE INVENTION

5 This invention relates generally to implants for repairing ducts and passageways in the body. More specifically, the invention relates to an apparatus and procedures for deploying a stent-graft in mammalian vasculature.

A variety of stent or stent-graft designs and deployment mechanisms have been developed. For various reasons, many of these stent-grafts tend to become displaced from the intended deployment site within a lumen upon deployment prior to being secured within the lumen. Thus, there is a need to improve stent or  
10 stent-graft deployment placement accuracy and reliability within a vessel. Additionally, there exists a need to improve upon the reliability of the devices used for deployment of the stent-grafts.

### SUMMARY OF THE INVENTION

15 The present invention involves medical devices and method(s) for deploying an expandable stent or stent-graft within mammalian lumens. According to the invention, a medical device comprises a stent (or stent-graft) which has a proximal portion and a distal portion, and means, releasably coupled to the stent or (stent graft), for progressively deploying or expanding the stent  
20 from its proximal to distal portion. According to one preferred embodiment, the means comprises a tether or slip line, which is releaseably coupled to the stent. The line is arranged such that when it is released from the stent, the stent progressively expands in a direction from its proximal portion to its distal portion. In order to accomplish progressive expansion of the stent according to one  
25 variation of the slip line embodiment, the line is preferably arranged in a sack knot configuration. According to a further aspect of the slip line embodiment, the line has a fixed end associated with the distal portion of the stent and a release end associated with the proximal portion of the stent. The release end of the line is pullable to actuate expansion of the stent.

The position of the line and the sack knot configuration can eliminate the need for doubling back the line to minimize the risk of snagging between the line and the stent device, thus, increasing deployment reliability.

5 According to another aspect of the invention, the stent or stent-graft described above may be placed within a lumen from a direction against the flow of fluid (*e.g.*, blood). The stent can expand or unfold in a direction from its downstream end to its upstream end relative to the fluid flow. Thus, the present invention may minimize the likelihood of the device being displaced from the desired site before it is somewhat secured in the vessel during deployment.

10 According to another aspect of the invention, a delivery member, such as a catheter or guide wire, may be used to place the stent or stent-graft at the intended delivery site. When used with a catheter, the stent is releasably restrained in a collapsed state for delivery to a desired site where the stent is external to the catheter with its proximal end adjacent to the distal end of the delivery member or  
15 catheter shaft.

A preferred method of the present invention involves placing a folded stent device attached to a stent delivery member, such as a catheter, at a desired site within a mammalian lumen, and then progressively unfolding the stent device in a direction away from the stent delivery member.

20 The above is a brief description of some deficiencies in the prior art and advantages of the present invention. Other features, advantages, and embodiments of the invention will be apparent to those skilled in the art from the following description, accompanying drawings and appended claims.

#### BRIEF DESCRIPTION OF THE DRAWINGS

25 Fig. 1 is a diagrammatic perspective view of a folded stent-graft held in position by a tether line in a sack knot configuration in accordance with the principles of the present invention.

Fig. 2 shows an enlarged view of a stent fold line using the tether line in the sack knot configuration of Fig. 1.

Fig. 3A is a perspective view of the stent-graft Fig. 1 in an unfolded state.

Fig. 3B is an enlarged perspective view of a mid-portion of the stent-graft of Fig. 3A.

5 Figs. 4A, 4B, and 4C diagrammatically show a method of deploying a stent-graft according to the present invention for deploying the stent graft shown in Fig. 1

### DETAILED DESCRIPTION OF THE INVENTION

Referring to the drawings generally, wherein like numerals indicate like elements throughout the several drawings, and to Fig. 1 in particular, there is  
10 shown a diagrammatic perspective view of an exemplary stent-graft 302 folded and constrained by means of a tether or slip line configuration 309 (Figs. 1 and 2) in accordance with the principles of the present invention. Although a particular stent-graft will be described, it should be understood that this description is for the purpose of presenting an example, and that other stent-graft constructions can be  
15 used. The stent fold line configurations and deployment methods of the present invention, which are discussed in detail below with respect to Figs. 1, 2, and 4A-C, may be employed with a variety of stent-graft configurations such as that illustrated in Figs. 3A and 3B. The exemplary stent-graft configuration of Figs. 3A and 3B is discussed first in order to shed light on the description of the  
20 deployment apparatus and methods of the present invention.

Fig. 3A shows an expandable stent-graft 2. Expandable stent-graft 2 generally includes a thin-walled tube or graft member 4, an expandable stent member 6, and a coupling member 8 for coupling the stent and graft members together. Stent member 6, which is disposed between generally tubular graft  
25 member 4 and coupling member 8, provides a support structure for graft member 4 to minimize the likelihood of graft member 4 collapsing during use.

Expandable stent member 6 is generally cylindrical and comprises a helically arranged undulating member 10 having a plurality of helical turns 12 and preferably comprises nitinol wire, although other materials may be used.

Undulating helical member 10 forms a plurality of undulations 14 which are preferably aligned so that they are generally "in-phase" with each other as shown in the drawings. A linking member 20 is provided to maintain the phased relationship of undulations 14 during compression and deployment as well as during bending of the stent member 6. As more clearly shown in the enlarged sectional view of Fig. 3B, linking member 20 is laced or interwoven between undulations in adjacent turns of helical member 10 and, thus, acquires a helical configuration as well. Linking member 20 preferably comprises a biocompatible polymeric or metallic material having sufficient flexibility to be readily folded upon itself.

Coupling member 8, which secures the stent member to the graft member 4, covers only a portion of the stent member 6. Alternatively, coupling member 8 can be described as preferably interconnecting less than entirely the inner or outer surface of stent member 6 to graft member 4 (*e.g.* it covers less than all of the outer surface of stent member 6 when graft member 4 is positioned inside stent member 6). With this construction, regions of the stent member do not interface with the coupling member when the stent-graft is an uncompressed state, for example. This is believed to advantageously reduce shear stresses between the stent member and the coupling member when the stent-graft undergoes bending or compression, thereby reducing the risk of tearing the graft or coupling member or causing delamination between the stent and graft members.

Coupling member 8 preferably has a generally broad or flat surface for interfacing with the stent 6 and graft members 4, and is arranged in a helical configuration. This broad surface increases the potential bonding surface area between coupling member 8 and graft member 4 to enhance the structural integrity of the stent-graft. The increased bonding surface area also facilitates minimizing the thickness of the coupling member. It has been found that a coupling member 8 in the form of a generally flat ribbon or tape, as shown in the enlarged sectional view of Fig. 3B, provides preferable results.

In Fig. 3B, coupling member 8 is shown formed with multiple helical turns 23, each being spaced from the turns adjacent thereto, thereby forming coupling member-free stress relief zones 24 between adjacent turns. The coupling member also preferably is arranged to provide a generally uniform distribution of stress relief zones 24. In the illustrated embodiment, coupling member 8 is helically wound around stent member 6 with its helical turns 23 aligned with the stent member turns 12.

Coupling member 8 also preferably covers a substantial portion of each undulation 14 so as to minimize the likelihood of stent member 6 lifting away from graft member 4. As shown, the coupling member may be constructed with a constant width and arranged with uniform spacing between the turns. Coupling members having widths of 0.025, 0.050, and 0.075 inches have been applied to the illustrated stent member having a peak-to-peak undulation amplitude of about 0.075 inch with suitable results. However, it has been found that as the coupling member band width increases, the stent-graft flexibility generally is diminished. It is believed that a coupling member width of about one-fourth to three-fourths the amplitude of undulations 14, measured peak-to-peak, is preferred (and more preferably one-third to two-thirds) to optimize flexibility. Coupling member 8 (or separate pieces thereof) preferably also surrounds the terminal end portions 16 and 18 of stent-graft 2 to secure the terminal portions of graft member 4 to the support the structure formed by stent member 6.

It should be noted that the above-described stent-graft configuration of Figs. 1, 3A and 3B is only exemplary. Other stent-graft configurations and constructions can be used with the present invention, such as those disclosed in PCT Publication WO 95/26695, which is hereby incorporated by reference herein in its entirety.

The scope of materials suitable for the stent and graft members and the linking member described above as well as deployment mechanisms will be discussed in detail below.

### Stent Materials

The stent member is constructed of a reasonably high strength material, *i.e.*, one which is resistant to plastic deformation when stressed. Preferably, the stent member comprises a wire which is helically wound around a mandrel having pins arranged thereon so that the helical turns and undulations can be formed simultaneously. Other constructions also may be used. For example, an appropriate shape may be formed from a flat stock and wound into a cylinder or a length of tubing formed into an appropriate shape.

In order to minimize the wall thickness of the stent-graft, the stent material should have a high strength-to-volume ratio. Designs as depicted herein provide stents which may be longer in length than conventional designs. Additionally, the designs do not suffer from a tendency to twist (or helically unwind) or to shorten as the stent-graft is deployed. As will be discussed below, materials suitable in these stents and meeting these criteria include various metals and some polymers.

A percutaneously delivered stent-graft must expand from a reduced diameter, necessary for delivery, to a larger deployed diameter. The diameters of these devices obviously vary with the size of the body lumen into which they are placed. For instance, the stents may range in size from 2.0 mm in diameter for neurological applications to 40 mm in diameter for placement in the aorta. Typically, expansion ratios of 2:1 or more are required. These stents are capable of expansion ratios of up to 5:1 for larger diameter stents. The thickness of the stent materials obviously varies with the size (or diameter) of the stent and the ultimate required yield strength of the folded stent. These values are further dependent upon the selected materials of construction. Wire used in these variations are typically of stronger alloys, *e.g.*, nitinol and stronger spring stainless steels, and have diameters of about 0.002 inches to 0.005 inches. For the larger stents, the appropriate diameter for the stent wire may be somewhat larger, *e.g.*, 0.005 to 0.020 inches. For flat stock metallic stents, thicknesses of about 0.002 inches to 0.005 inches is usually sufficient. For the larger stents, the appropriate



thickness for the stent flat stock may be somewhat thicker, *e.g.*, 0.005 to 0.020 inches.

The stent-graft is fabricated in the expanded configuration. In order to reduce its diameter for delivery the stent-graft would be folded along its length, similar to the way in which a PCTA balloon would be folded. It is desirable, when using super-elastic alloys which also have temperature-memory characteristics, to reduce the diameter of the stent at a temperature below the transition-temperature of the alloys. Often the phase of the alloy at the lower temperature is somewhat more workable and easily formed. The temperature of deployment is desirably above the transition temperature to allow use of the super-elastic properties of the alloy.

There are a variety of disclosures in which super-elastic alloys such as nitinol are used in stents. See, U.S. Patent Nos. 4,503,569, to Dotter; 4,512,338, to Balko *et al.*; 4,990,155, to Wilkoff; 5,037,427, to Harada, *et al.*; 5,147,370, to MacNamara *et al.*; 5,211,658, to Clouse; and 5,221,261, to Termin *et al.* None of these references suggest a device having discrete, individual, energy-storing torsional members.

Jervis, in U.S. Pat. Nos. 4,665,906 and 5,067,957, describes the use of shape memory alloys having stress-induced martensite properties in medical devices which are implantable or, at least, introduced into the human body.

A variety of materials variously metallic, super elastic alloys, and preferably nitinol, are suitable for use in these stents. Primary requirements of the materials are that they be suitably springy even when fashioned into very thin sheets or small diameter wires. Various stainless steels which have been physically, chemically, and otherwise treated to produce high springiness are suitable as are other metal alloys such as cobalt chrome alloys (*e.g.*, ELGILOY<sup>®</sup>), platinum/tungsten alloys, and especially the nickel-titanium alloys generically known as "nitinol".

Nitinol is especially preferred because of its "super-elastic" or "pseudo-elastic" shape recovery properties, *i.e.*, the ability to withstand a significant amount of bending and flexing and yet return to its original form without deformation. These metals are characterized by their ability to be transformed from an austenitic crystal structure to a stress-induced martensitic structure at certain temperatures, and to return elastically to the austenitic shape when the stress is released. These alternating crystalline structures provide the alloy with its super-elastic properties. These alloys are well known but are described in U.S. Pat. Nos. 3,174,851, 3,351,463, and 3,753,700. Typically, nitinol will be nominally 50.6% ( $\pm 0.2\%$ ) Ni with the remainder Ti. Commercially available nitinol materials usually will be sequentially mixed, cast, formed, and separately cold-worked to 30-40%, annealed, and stretched. Nominal ultimate yield strength values for commercial nitinol are in the range of 30 psi and for Young's modulus are about 700 Kbar. The '700 patent describes an alloy containing a higher iron content and consequently has a higher modulus than the Ni-Ti alloys.

Nitinol is further suitable because it has a relatively high strength to volume ratio. This allows the torsion members to be shorter than for less elastic metals. The flexibility of the stent-graft is largely dictated by the length of the torsion segments and/or torsion arms. The shorter the pitch of the device, the more flexible the stent-graft structure can be made. Materials other than nitinol are suitable. Spring tempered stainless steels and cobalt-chromium alloys such as ELGILOY<sup>®</sup> are also suitable as are a wide variety of other known "super-elastic" alloys.

Although nitinol is preferred in this service because of its physical properties and its significant history in implantable medical devices, we also consider it also to be useful in a stent because of its overall suitability with magnetic resonance imaging (MRI) technology. Many other alloys, particularly those based on iron, are an anathema to the practice of MRI causing exceptionally

poor images in the region of the alloy implant. Nitinol does not cause such problems.

Other materials suitable as the stent include certain polymeric materials, particularly engineering plastics such as thermotropic liquid crystal polymers ("LCP's"). These polymers are high molecular weight materials which can exist in a so-called "liquid crystalline state" where the material has some of the properties of a liquid (in that it can flow) but retains the long range molecular order of a crystal. The term "thermotropic" refers to the class of LCP's which are formed by temperature adjustment. LCP's may be prepared from monomers such as p,p'-dihydroxy-polynuclear-aromatics or dicarboxy-polynuclear-aromatics. The LCP's are easily formed and retain the necessary interpolymer attraction at room temperature to act as high strength plastic artifacts as are needed as a foldable stent. They are particularly suitable when augmented or filled with fibers such as those of the metals or alloys discussed below. It is to be noted that the fibers need not be linear but may have some preforming such as corrugations which add to the physical torsion enhancing abilities of the composite.

#### Linking Member Materials

Flexible link 20, which is slidably disposed between adjacent turns of the helix may be of any appropriate filamentary material which is blood compatible or biocompatible and sufficiently flexible to allow the stent to flex and not deform the stent upon folding. Although the linkage may be a single or multiple strand wire (platinum, platinum/tungsten, gold, palladium, tantalum, stainless steel, etc.), the use of polymeric biocompatible filaments is preferable. Synthetic polymers such as polyethylene, polypropylene, polyurethane, polyglycolic acid, polyesters, polyamides, their mixtures, blends and copolymers are suitable; preferred of this class are polyesters such as polyethylene terephthalate including DACRON<sup>®</sup> and MYLAR<sup>®</sup> and polyaramids such as KEVLAR<sup>®</sup>, polyfluorocarbons such as polytetrafluoroethylene with and without copolymerized hexafluoropropylene

(TEFLON<sup>®</sup> or GORE-TEX<sup>®</sup>), and porous or nonporous polyurethanes. Natural materials or materials based on natural sources such as collagen may also be used.

#### Graft Member Materials

5 The tubular component or graft member of the stent-graft may be made up of any material which is suitable for use as a graft in the chosen body lumen. Many graft materials are known, particularly known are those used as vascular graft materials. For instance, natural materials such as collagen may be introduced onto the inner surface of the stent and fastened into place. Desirable collagen-based materials include those described in U.S. Pat. No. 5,162,430, Rhee *et al.*, and WO 94/01483 (PCT/US93/06292), the entirety of which are  
10 incorporated by reference. Synthetic polymers such as polyethylene, polypropylene, polyurethane, polyglycolic acid, polyesters, polyamides, their mixtures, blends and copolymers are suitable; preferred of this class are polyesters such as polyethylene terephthalate including DACRON<sup>®</sup> and MYLAR<sup>®</sup> and  
15 polyaramids such as KEVLAR<sup>®</sup>, polyfluorocarbons such as polytetrafluoroethylene (PTFE) with and without copolymerized hexafluoropropylene (TEFLON<sup>®</sup> or GORE-TEX<sup>®</sup>), and porous or nonporous polyurethanes. Especially preferred are the expanded fluorocarbon polymers (especially PTFE) materials described in British. Pat. Nos. 1,355,373, 1,506,432, or 1,506,432 or in U.S. Pat. Nos. 3,953,566, 4,187,390, or 5,276,276, the entirety  
20 of which are incorporated by reference.

Included in the class of preferred fluoropolymers are polytetrafluoroethylene (PTFE), fluorinated ethylene propylene (FEP), copolymers of tetrafluoroethylene (TFE) and perfluoro (propyl vinyl ether) (PFA),  
25 homopolymers of polychlorotrifluoroethylene (PCTFE), and its copolymers with TFE, ethylene-chlorotrifluoroethylene (ECTFE), copolymers of ethylene-tetrafluoroethylene (ETFE), polyvinylidene fluoride (PVDF), and polyvinyl fluoride (PVF). Especially preferred, because of its widespread use in vascular prostheses, is expanded PTFE.

In addition, one or more radio-opaque metallic fibers, such as gold, platinum, platinum-tungsten, palladium, platinum-iridium, rhodium, tantalum, or alloys or composites of these metals like may be incorporated into the device, particularly, into the graft, to allow fluoroscopic visualization of the device.

5 The tubular component may also be reinforced using a network of small diameter fibers. The fibers may be random, braided, knitted, or woven. The fibers may be imbedded in the tubular component, may be placed in a separate layer coaxial with the tubular component, or may be used in a combination of the two.

10 A preferred material for the graft and coupling members is porous expanded polytetrafluorethylene. An FEP coating is one preferred adhesive that is provided on one side of the coupling member.

#### Manufacture of the Stent-Graft

15 The following example is provided for purposes of illustrating a preferred method of manufacturing a stent-graft such as the one shown in Figs. 3A and 3B. It should be noted, however, that this example is not intended to limit the invention.

20 The stent member wire is helically wound around a mandrel having pins positioned thereon so that the helical structure and undulations can be formed simultaneously. While still on the mandrel, the stent member is heated to about 460°F for about 20 minutes so that it retains its shape.

25 Wire sizes and materials may vary widely depending on the application. The following is an example construction for a stent-graft designed to accommodate a 6 mm diameter vessel lumen. The stent member comprises a nitinol wire (50.8 atomic % Ni) having a diameter of about 0.007 inch. In this example case, the wire is formed to have sinusoidal undulations, each having an amplitude measured peak-to-peak of about 0.100 inch and the helix is formed with a pitch of about 10 windings per inch. The inner diameter of the helix (when

unconstrained) is about 6.8 mm. The linking member can be arranged as shown in the drawings and may have a diameter of about 0.006 inch.

In this example, the graft member is porous expanded polytetrafluorethylene (PTFE), while the coupling member is expanded PTFE coated with FEP. The coupling member is in the form of a flat ribbon (as shown in the illustrative embodiments) that is positioned around the stent and graft members as shown in Fig. 3B. The side of the coupling member or ribbon that is FEP coated faces the graft member to secure it to the graft member. The intermediate stent-graft construction is heated to allow the materials of the ribbon and graft member to merge and self-bind as will be described in more detail below.

The FEP-coated porous expanded PTFE film used to form the ribbon shaped coupling member preferably is made by a process which comprises the steps of:

- (a) contacting a porous PTFE film with another layer which is preferably a film of FEP or alternatively of another thermoplastic polymer;
- (b) heating the composition obtained in step (a) to a temperature above the melting point of the thermoplastic polymer;
- (c) stretching the heated composition of step (b) while maintaining the temperature above the melting point of the thermoplastic polymer; and
- (d) cooling the product of step (c).

In addition to FEP, other thermoplastic polymers including thermoplastic fluoropolymers may also be used to make this coated film. The adhesive coating on the porous expanded PTFE film may be either continuous (non-porous) or discontinuous (porous) depending primarily on the amount and rate of stretching, the temperature during stretching, and the thickness of the adhesive prior to stretching.

The thin wall expanded PTFE graft used to construct this example is of about .1 mm (0.004 in) thickness and had a density of about 0.5g/cc. The

microstructure of the porous expanded PTFE contains fibrils of about 25 micron length. A 3 cm length of this graft material is placed on a mandrel the same diameter as the inner diameter of the graft. The nitinol stent member having about a 3 cm length is then carefully fitted over the center of the thin wall graft.

5           The stent-member was then provided with a ribbon shaped coupling member comprised of the FEP coated film as described above. The coupling member was helically wrapped around the exterior surface of the stent-member as shown in Fig. 3B. The ribbon shaped coupling member was oriented so that its FEP-coated side faced inward and contacted the exterior surface of the  
10           member. This ribbon surface was exposed to the outward facing surface of the thin wall graft member exposed through the openings in the stent member. The uniaxially-oriented fibrils of the microstructure of the helically-wrapped ribbon were helically-oriented about the exterior stent surface.

          The mandrel assembly was placed into an oven set at 315°C for a period of  
15           15 minutes after which the film-wrapped mandrel was removed from the oven and allowed to cool. Following cooling to approximately ambient temperature, the mandrel was removed from the resultant stent-graft. The amount of heat applied was adequate to melt the FEP-coating on the porous expanded PTFE film and thereby cause the graft and coupling members to adhere to each other. Thus, the  
20           graft member was adhesively bonded to the inner surface of helically-wrapped coupling member 8 through the openings between the adjacent wires of the stent member. The combined thickness of the luminal and exterior coverings (graft and coupling members) and the stent member was about 0.4 mm.

          The stent-graft was then folded in order to prepare it for delivery. To  
25           accomplish this a stainless steel wire which was longer than the stent-graft (more specifically a couple of, or about two, inches longer than the stent-graft, but that length can vary as it is not critical) was inserted through the lumen of the stent-graft. The stent-graft was flattened and the stainless steel wire positioned at one end of the stent-graft. A second stainless wire of about the same length was

placed on the outer surface of the stent-graft adjacent to the first stainless steel wire. The wires were then mounted together into a fixture, tensioned and then rotated, thereby folding the stent-graft. As the stent-graft rotates it is pressed into a "C" shaped elongated stainless steel clip in order to force it to roll upon itself.  
5 The folded stent-graft is then advanced along the wire out of the clip into a glass capture tube. A removable tether line, which is used to constrain the stent-graft in the rolled configuration for delivery is applied to the stent-graft at this point by gradually advancing the stent-graft out of the capture tube and lacing the tether line through the stent-graft structure. After this step is completed, the stent-graft  
10 is pulled off of the first wire and transferred onto the distal end of the catheter shaft or tubing for delivery.

Prior to folding, the stent-graft was cooled to about  $-30^{\circ}\text{C}$  so that the nitinol was fully martensitic and, thus, malleable. This is done to allow the stent-graft to be more easily folded. Cooling is accomplished by spray soaking the graft  
15 with chilled gas such as tetrafluoroethane. Micro-Dust™ dry circuit duster manufactured by MicroCare Corporation (Conn) provides suitable results. The spray canister was held upside down to discharge the fluid as a liquid onto the stent-graft.

#### 20 Deployment of the Stent-Graft

The stent-graft may be delivered percutaneously, typically through the vasculature, after having been folded to a reduced diameter. Once reaching the intended delivery site, it may be expanded to form a lining on the vessel wall.

25 When a stent-graft having torsion members, as in the stent-graft described above and shown in the drawings, is folded, crushed, or otherwise collapsed, mechanical energy is stored in torsion in those members. The portions of the undulations extending between the bends can be loaded in torsion when the bends are twisted such as when the stent-graft is folded along or near a number of those portions as shown in Fig. 1. In this loaded state, the torsion members have a



torque exerted about them and consequently have a tendency to untwist. Collectively, the torque exerted by the torsion members as folded down to a reduced diameter must be restrained from springing open as is apparent from the foregoing, it is a self-expanding stent-graft. The stent-member preferably has at least one torsion member per fold. The stent-graft is folded along its longitudinal axis and restrained from springing open. The stent-graft is then deployed by removing the restraining mechanism, thus allowing the torsion members to spring open against the vessel wall. The attending physician will select an appropriately sized stent-graft. Typically, the stent-graft will be selected to have an expanded diameter of up to about 10% greater than the diameter of the lumen at the deployment site.

Figs. 4A-C diagrammatically show a procedure for deploying a stent-graft assembly, constructed according to the present invention, using a percutaneous dual-lumen catheter assembly 314. Catheter assembly 314 includes a catheter or delivery member shaft portion 325, a hub portion 327, and a tip portion 312. Extending coaxially within shaft portion 325 are two parallel channels, a guidewire channel 331 and a tether line channel 329. Shaft portion 325 has a distal end portion 310 and a proximal end portion 311 that is coupled or adapted for coupling to hub portion 327. Extending through guidewire channel 331 and beyond distal end portion 310 is a guidewire tube 318. Running through and extending distally beyond the end of guidewire tube 318 is guidewire 319. Axially mounted on the distal end of guidewire tube 318 are a proximal barrier 321 and a distal barrier 320.

Referring particularly to Fig. 4A, catheter assembly 314 has been inserted into a selected site within a body lumen 350. A stent-graft, such as stent-graft 2, which is described in conjunction with Figs. 1, 3A and 3B, is folded about guidewire tube 318 and is held axially in place prior to deployment between the distal and proximal barriers 320, 321. Tether wire or slip line 306 extends through loops 324, 326 and through tether line channel 325 and hub portion 327

of catheter assembly 314 to outside the body. Tether wire 306 may be outside proximal barrier 321 or extend therethrough as shown in Fig. 4A.

5 Deployment of stent-graft 2 is accomplished by actuating or pulling tether wire 306 in the direction of arrow 370, as shown in Fig. 4B. Fig. 4B shows partial removal of tether wire 306 from eyelets or loops 324, 326 to partially deploy and expand the stent-graft 2 onto the selected site. With this configuration, stent-graft 2 can be described as opening, progressively radially expanding or deploying in a hub-to-tip direction with respect to catheter assembly 314 and in a proximal-to-  
10 distal direction with respect to the stent-graft itself (*i.e.*, the end of the stent-graft proximate to distal end portion 310 of shaft portion 325 opens first). Stent-graft 2 may further be described with reference to Fig. 4B as opening or progressively radially expanding in a direction away from the distal end portion 310 of catheter shaft portion 325 or in a proximal to distal direction with respect to proximal and  
15 distal catheter shaft portions 311 and 310, respectively. Fig. 4C shows tether wire 306, the loops thereof have been completely retracted from the interior of stent-graft 2, which is now in its fully unfolded, deployed state within lumen 350.

The hub-to-tip or proximal-to-distal deployment method of the present invention, described above with respect to Figs. 4A-C, is accomplished in part by the manner in which the tether or slip line is configured to the stent-graft. Figs. 1  
20 and 2 show a preferred embodiment of the tether line configuration of the present invention. In Fig. 1, stent-graft 2 is shown having a proximal portion 330 and a distal portion 332. When stent-graft 2 is used for its intended purpose in conjunction with a deployment means, such as the catheter assembly 314 illustrated in Figs. 4A-C, proximal portion 330 is positioned proximate to and  
25 associated with distal end 310 of catheter assembly 314. As such, distal portion 332 of stent-graft 2 is positioned proximate to and associated with the tip portion 312 of catheter assembly 314.

In the embodiment illustrated in the drawings, stent-graft 2 is held in position by a tether or slip line, generally designated with reference numeral 306

which can be in a sack knot configuration as generally designated with reference numeral 309 in accordance with the present invention. Fig. 1 shows the use of a particular number of stent folds 2 for purposes of example as other folding or collapsed configurations may be used. The fixed end portion 320 of slip line 306 is associated with distal end 332 of stent-graft 2 and a row of eyelets 324. Conversely, the release end 322 of slip line 306 is associated with proximal end 330 of stent-graft 2. The eyelets are preferably formed by pulling local portions of linking member 20 away from the fold line, threading slip line 306 therethrough, and then releasing the respective portion of linking member 20. The eyelets may then be tied or otherwise fixed to the stent.

Figs. 1 and 2 show the slip line 306 having the herringbone pattern of the "sack knot" configuration used to close the upper folds 302 in stent 2 as shown in Fig. 1. This knot is the one used to hold, for example, burlap sacks of feed grain closed prior to use which allow ease of opening when the sack is to be opened. Slip line 306 has a fixed end 320 and a release end 322. Loops of slip line 306 pass through the eyelets 324 on the side of the stent fold associated with the fixed end 320. It should also be noted that the fixed end 320 is not typically tied to stent 2 so as to allow removal of the slip line after deployment. Additionally, the eyelets 324 and 326 are desirable but optional. The eyelets 324 and 326 may be wire or polymeric thread or the like tied to the stent structure at the edge of the stent fold. Alternatively, eyelets 324 and 326 may be formed from linking member 20, as discussed above, to form the loops of slip line 306. In a further configuration, slip line 306 may be woven into the stent structure, for example, into undulations 14 as shown in Fig. 3A.

Release end 322 of slip line 306 is positioned so that, when the catheter assembly 314 is associated with stent-graft 2 as shown in Figs. 4A and 4B, distal end portion 310 of shaft portion 325 is in the vicinity of or adjacent to the proximal portion 330 of stent-graft 2. Thus, when release end 322 is pulled in the

direction of arrow 334, the stent-graft 2 unfolds from the proximal end 330 to the distal end 332 (see Fig. 4B).

5 If the release end of the slip line were doubled back along eyelets 326, as depicted in phantom in Fig. 2, and release end 322 positioned adjacent to distal end portion 310 of catheter shaft 325, pulling release end 322 in the direction of arrow 336 would result in stent-graft 2 unfolding in the opposite direction, from distal end 332 towards proximal end 330. This distal-to-proximal unfolding arrangement, due to the extra folded-back length of the tether line leading to release end 322, is more likely to cause the tether line to become entangled upon  
10 deployment of the stent-graft.

The preferred proximal-to-distal deployment arrangement eliminates the extra folded-back length of the tether line leading to the release end and, thus, may reduce the likelihood of snagging between the slip line and stent member. This arrangement also provides less fluid flow resistance when the stent-graft is  
15 deployed against the flow of blood (*i.e.*, from a downstream to upstream direction), which in turn improves positioning accuracy during deployment, particularly in the course of an aortic procedure. Other means, within the scope of the invention, may be employed to hold the stent device in a folded, collapsed or constricted configuration and to provide proximal-to-distal deployment in  
20 accordance with the present invention. These means include adhesive tape having a perforation which facilitates easy tear-away, a Velcro strip that can be peeled away from a stent or stent-graft device, a zipper or clasp mechanism, or any other suitable interlocking-type mechanism having a pull actuator. In addition, other slip line constructions may be used. For example, the slip line can comprise a  
25 metallic (e.g., 304 stainless steel) portion and a nonmetallic (e.g., ePTFE) portion, the latter being used to form the slip knot for the stent or stent-graft. The metal portion may be described as the proximal portion and the nonmetallic portion as the distal portion. The metal portion may be formed with an eyelet, which may be formed by folding one end of the metallic portion back upon itself, for receipt of

the nonmetallic portion, which may then be tied thereto. Other connections, however, may also be used.

The disclosures of any publications, patents and published patent applications referred to in this application are hereby incorporated by reference.

5           The above is a detailed description of a particular embodiment of the invention. The full scope of the invention is set out in the claims that follow and their equivalents. Accordingly, the claims and specification should not be construed to unduly narrow the full scope of protection to which the invention is entitled.

CLAIMS

1. A medical device comprising:  
a stent having a proximal portion and a distal portion, and  
a line releaseably coupled to said stent to hold said stent in a folded  
state, said line being arranged to be released wherein said stent progressively  
expands in a direction from said proximal portion to said distal portion.
2. The device of claim 1 wherein said line is arranged in a sack knot  
configuration.
3. The device of claim 2 wherein said sack knot configuration has a  
herringbone pattern.
4. The device of claim 1 wherein said line comprises a fixed end  
associated with said distal portion of said stent and a release end associated with  
said proximal portion of said stent, said release end being pullable to actuate  
expansion of said stent.
5. The device of claim 1 in combination with a deployment device  
wherein said proximal portion of said stent is positioned proximate to said  
deployment device and said distal portion of said stent is positioned distally with  
respect to said deployment device.
6. The device of claim 5 further including a graft coupled to said  
stent.
7. A stent assembly comprising:  
a stent having a folded configuration, an unfolded configuration,  
and first and second end portions;

a delivery member coupled to said stent, said first end portion of said stent positioned adjacent to said delivery member and said second end portion of said stent positioned distally from said delivery member; and

5 a deployment mechanism coupled to said stent to hold said stent in said folded configuration, said deployment mechanism being arranged to be released from said stent progressively in a direction wherein said stent progressively obtains said unfolded configuration in a direction from said first end portion to said second end portion.

10 8. The stent assembly of claim 7 wherein said deployment mechanism is a tether line comprising a release end associated with said first end portion of said stent and a fixed end associated with said second end portion of said stent, said release end being pullable to actuate deployment of said stent.

15 9. The stent assembly of claim 8 wherein said delivery member comprises a tube and further wherein said release end of said tether line extends through said tube.

20 10. The assembly of claim 7 further including a graft member coupled to said stent.

11. A stent deployment apparatus comprising:  
a generally tubular stent having a constricted configuration and an expanded configuration;  
25 a delivery member for placing said stent in a desired site within mammalian vasculature, said delivery member having a shaft portion and a tip portion wherein said stent is positioned between said tip portion and said shaft portion; and

5 a tether line releaseably coupled to said stent to hold said stent in said constricted configuration, said tether line being arranged to be released from said stent progressively in a direction such that said stent may progressively obtain said expanded configuration in a direction from said shaft portion to said tip portion of said delivery member.

10 12. The apparatus of claim 11 wherein said tether line comprises a first end associated with said shaft portion and a second end associated with said tip portion, said second end being pullable to actuate deployment of said stent-graft.

13. The apparatus of claim 11 wherein said delivery member is a catheter assembly.

15 14. The apparatus of claim 13 wherein said catheter assembly comprises a guidewire threaded therethrough for guiding said catheter assembly through said mammalian vasculature to said desired site, said guidewire extending from said shaft portion to said tip portion, said stent-graft is folded about said guidewire when in said constricted configuration.

20 15. The apparatus of claim 14 wherein said catheter assembly comprises a proximal barrier and a distal barrier axially positioned on said guidewire, said proximal barrier being proximate to said shaft portion and said distal barrier being proximate said tip portion such that said stent is axially held between said proximal and distal barriers when in said constricted configuration.

25 16. The apparatus of claim 11 wherein said stent comprises a helical member and a linking member, said helical member having multiple helical turns wherein adjacent turns are in-phase with one another, and said linking member links a number of adjacent helical turns to maintain said helical turns generally in-



phase with one another, and further wherein said tether line is releaseably coupled to said linking member.

5 17. The apparatus of claim 16 wherein said linking member forms first and second rows of eyelets on said stent-graft, and wherein said tether line is threaded through a number of said eyelets.

10 18. The apparatus of claim 17 wherein said tether line comprises a release end associated with said shaft portion and said first row of eyelets, and further comprises a fixed end associated with said tip portion and said second row of eyelets, said release end being pullable to actuate deployment of said stent-graft.

15 19. The apparatus of claim 10 further including a graft member coupled to said stent.

20 20. A medical device comprising:  
an expandable stent having a constricted configuration;  
a delivery member for placing said stent in a desired site within mammalian vasculature, said delivery member having a shaft portion and a tip portion wherein said stent is positioned between said tip portion and said shaft portion; and  
means releasably coupled to said stent for progressively deploying said stent, said means being in a direction from said shaft portion to said tip  
25 portion of said delivery member.

21. A method for deploying an expandable stent comprising the steps of:

placing a folded stent attached to a stent delivery member at a desired site within a mammalian lumen; and progressively unfolding said stent in a direction away from said stent delivery member.

5

22. The method of claim 21 wherein a slip line is releaseably attached to the stent for holding the stent in said folded condition and said unfolding step includes pulling said slip line.

10

23. The method of claim 22 wherein said delivery member is a catheter and said slip line is pulled in a direction toward said catheter.

24. The method of claim 21 wherein said stent is used in combination with a graft

15

25. A method for deploying an expandable stent comprising the steps of:  
placing a folded stent at a desired site with fluid flow in a mammal;  
and  
progressively expanding said stent in a direction against the fluid  
20 flow.

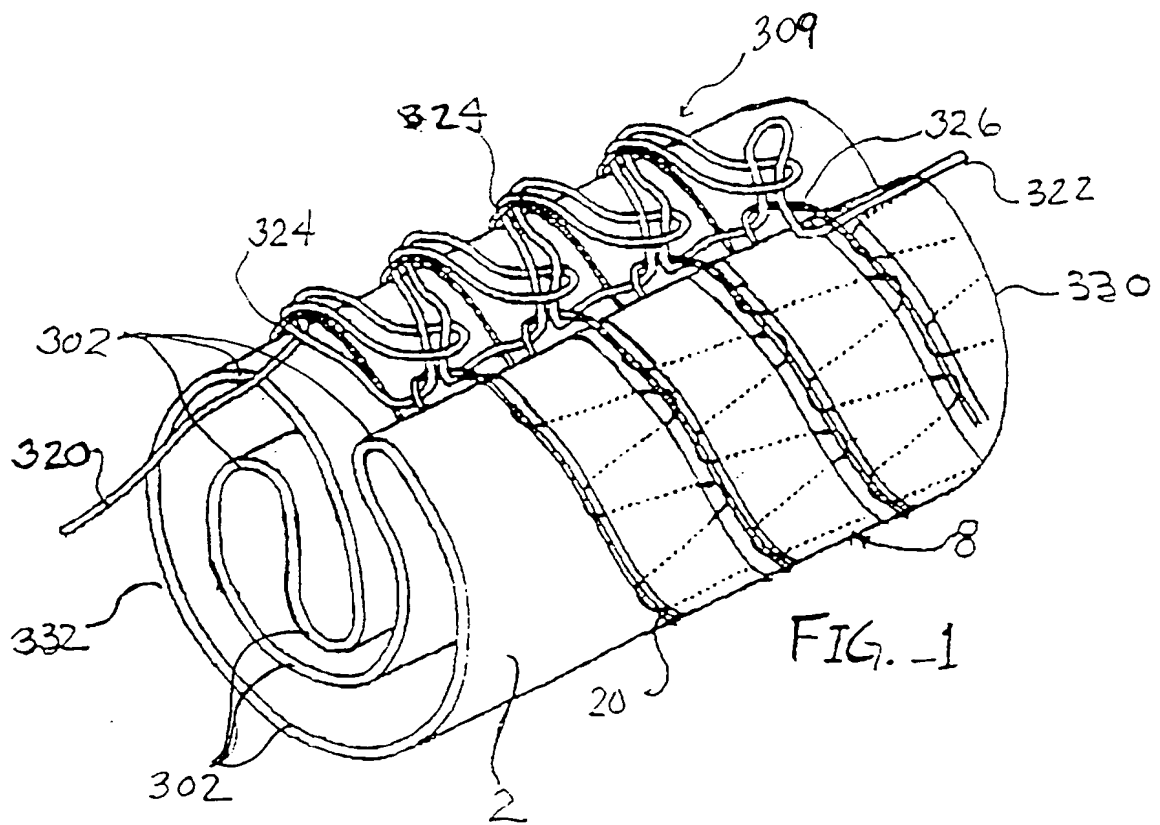
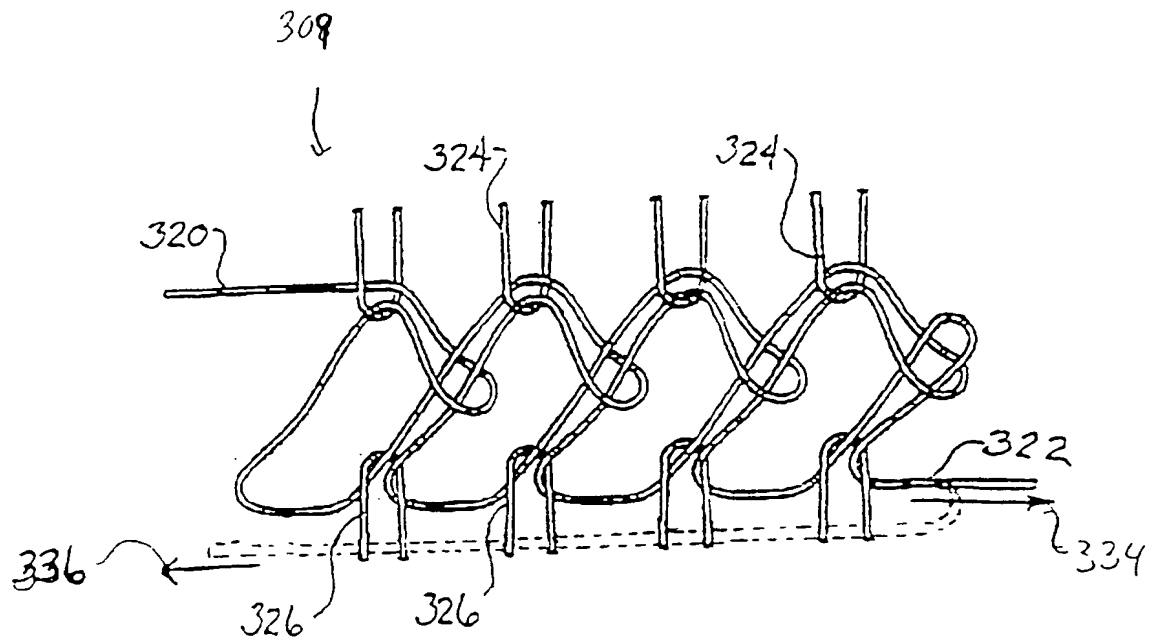

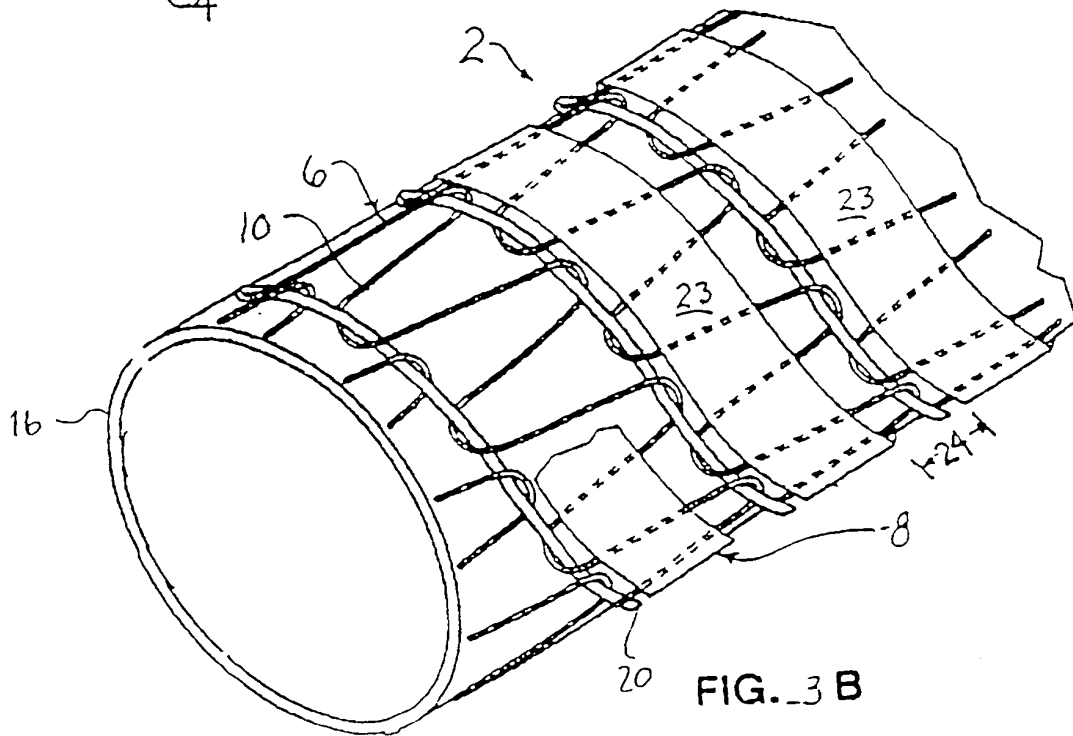
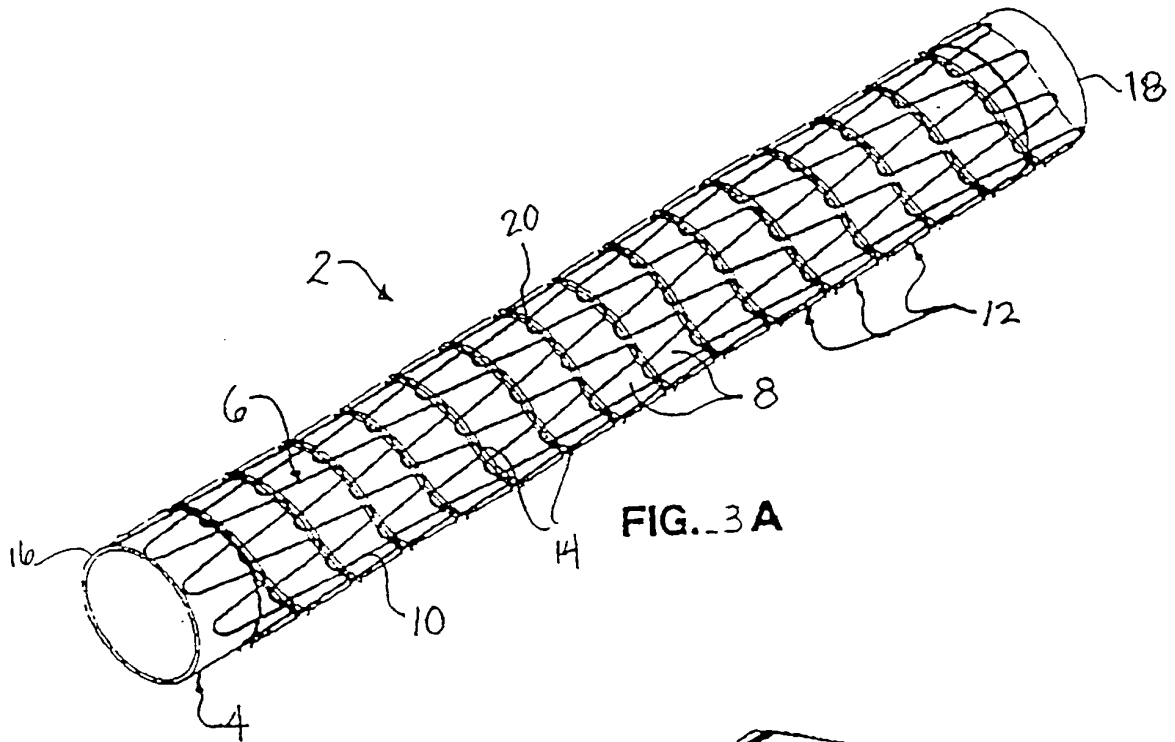

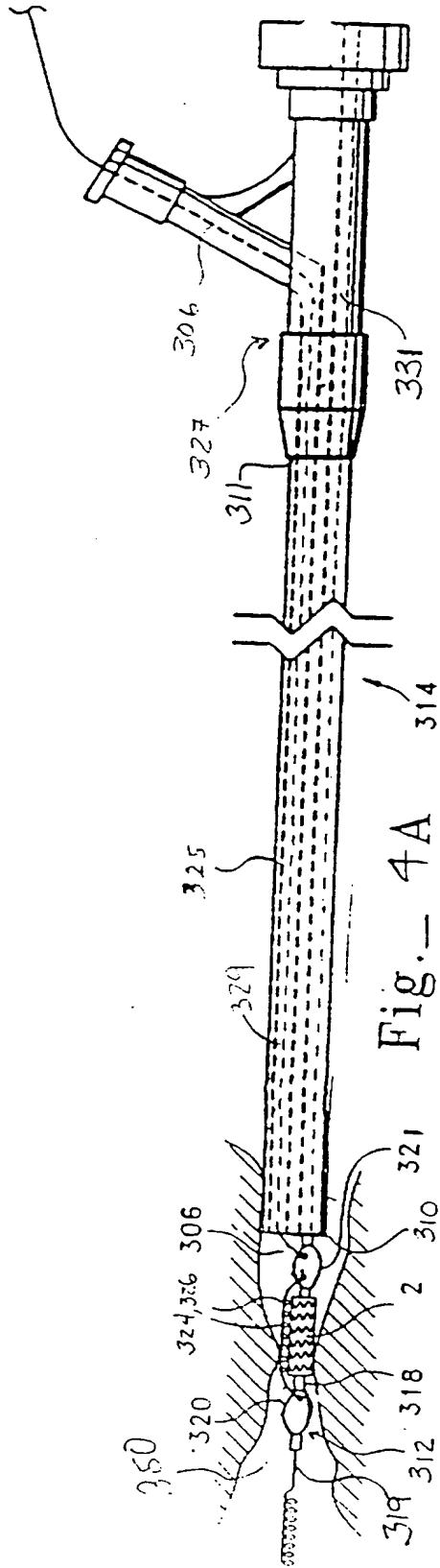

Fig.— 4A

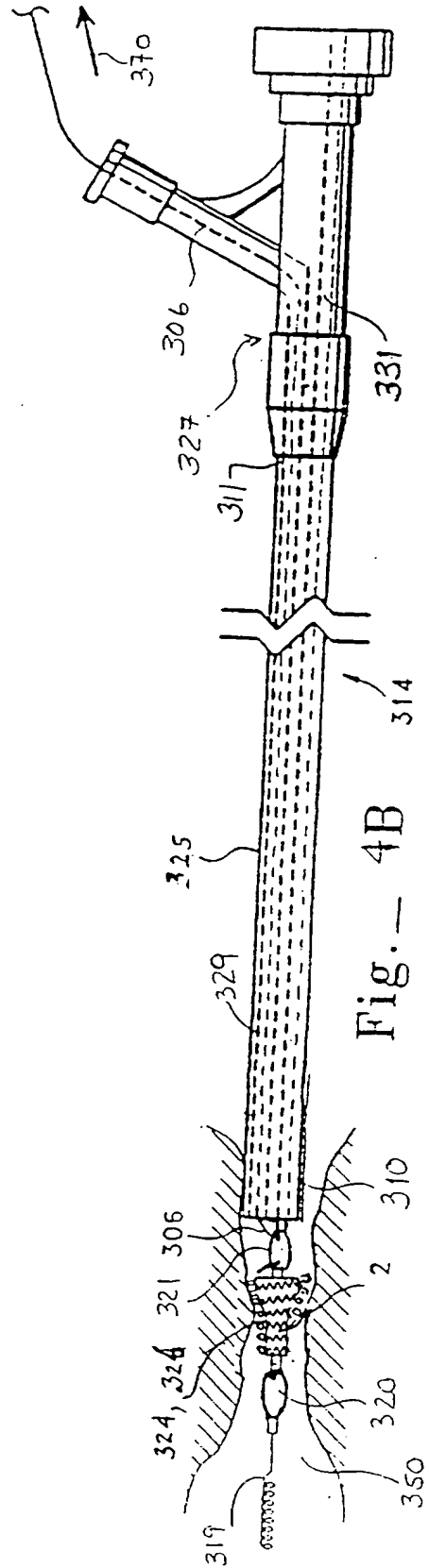

Fig.— 4B

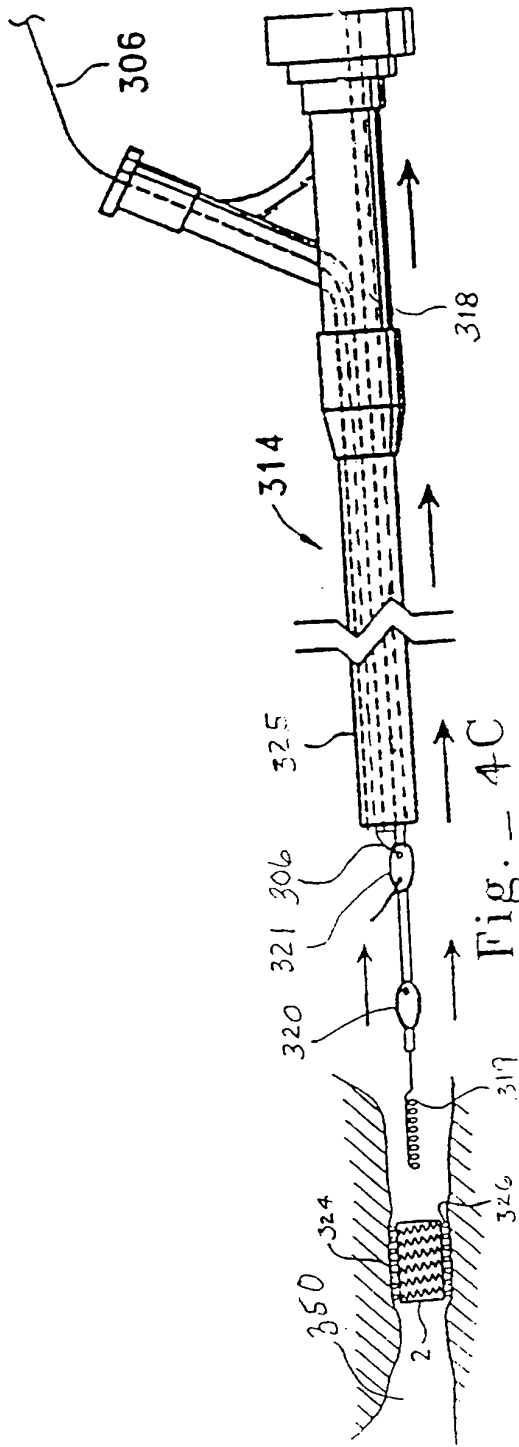

Fig. - 4C

INTERNATIONAL SEARCH REPORT

International application No.  
PCT/US96/19667

A. CLASSIFICATION OF SUBJECT MATTER

IPC(6) : A61F 2/06; A61M 29/02

US CL : 606/194; 623/1, 12

According to International Patent Classification (IPC) or to both national classification and IPC

B. FIELDS SEARCHED

Minimum documentation searched (classification system followed by classification symbols)

U.S. : 600/36; 606/194, 198; 623/1, 2, 11

Documentation searched other than minimum documentation to the extent that such documents are included in the fields searched

Electronic data base consulted during the international search (name of data base and, where practicable, search terms used)

C. DOCUMENTS CONSIDERED TO BE RELEVANT

Category*	Citation of document, with indication, where appropriate, of the relevant passages	Relevant to claim No.
X	US 5,405,378 A (STRECKER) 11 April 1995, col. 5, line 67 to col. 6, line 10.	1-5, 20
Y	US 5,282,824 A (GIANTURCO) 01 February 1994, abstract.	6
A,P	US 5,507,767 A (MAEDA et al) 16 April 1996.	1-25
A	US 4,913,141 A (HILLSTEAD) 03 April 1990.	1-25
A	US 5,035,706 A (GIANTUREO et al) 30 June 1991.	1-25

Further documents are listed in the continuation of Box C.  See patent family annex.

* Special categories of cited documents:	"T"	later document published after the international filing date or priority date and not in conflict with the application but cited to understand the principle or theory underlying the invention
"A" document defining the general state of the art which is not considered to be of particular relevance	"X"	document of particular relevance; the claimed invention cannot be considered novel or cannot be considered to involve an inventive step when the document is taken alone
"E" earlier document published on or after the international filing date	"Y"	document of particular relevance; the claimed invention cannot be considered to involve an inventive step when the document is combined with one or more other such documents, such combination being obvious to a person skilled in the art
"L" document which may throw doubts on priority claim(s) or which is cited to establish the publication date of another citation or other special reason (as specified)	"&"	document member of the same patent family
"O" document referring to an oral disclosure, use, exhibition or other means		
"P" document published prior to the international filing date but later than the priority date claimed		

Date of the actual completion of the international search 17 FEBRUARY 1997	Date of mailing of the international search report 04 MAR 1997
Name and mailing address of the ISA/US Commissioner of Patents and Trademarks Box PCT Washington, D.C. 20231 Facsimile No. (703) 305-3590	Authorized officer <i>Debra S. Brittingham</i> DEBRA S. BRITTINGHAM Telephone No. (703) 308-3401

Form PCT/ISA/210 (second sheet)(July 1992)\*

**THIS PAGE BLANK (USPTO)**